

CITY OF NORMANDY – REQUEST FOR PROPOSAL

Public Works Garage Roof Repair

OCTOBER 25, 2022
CITY OF NORMANDY
7700 Natural Bridge, St. Louis, MO 63121

Table of Contents

Public Notice -----	1
Request for Proposal -----	2-4
Bid Specifications -----	5-14
Drawings -----	15-18
Bid Form (must be completed and signed) -----	16-19

CITY OF NORMANDY REQUEST FOR PROPOSALS (RFP)

Public Works Garage Roof Repair

PUBLIC NOTICE

The City of Normandy, Missouri is seeking a qualified contractor the repair a roof at the Public Works Garage. Applicants shall provide a completed bid packet and all the necessary attachments in a sealed bid. There shall be a mandatory pre-bid site visit to Normandy Public Works, which will be held on November 9th at 11:30am.

Sealed proposals will be accepted until 10:00am, Tuesday November 15th, 2022, at which time there will be a public bid opening will be held at Normandy City Hall, 7700 Natural Bridge Road, Normandy, MO 63121. All bids should be placed in a sealed envelope with “ATTN: City Clerk, City of Normandy – Public Works Building” written on the envelope.

For itemized details of the scope of work, selection criteria, and specific requirements, please refer to the City’s webpage cityofnormandy.gov to get the full bid packet. All questions should be submitted in writing to Brent Boehringer at bboehringer@garlandind.com

Objective and Purpose

The City of Normandy, Missouri is seeking a qualified contractor for a labor only bid for the repair for a roof repair of the Public Works Garage.

Mandatory Site Visit

There shall be a mandatory pre-bid site visit to Normandy Public Works, 5800 Bermuda Road, St. Louis MO, 63121 which will be held on November 9th at 11:30am. Please contact Brent Boehringer (314-210-5870) for additional information.

Submission of Proposal

Sealed proposals will be accepted until 10:00am, Tuesday November 15th, 2022, at which time there will be a public bid opening will be held at Normandy City Hall, 7700 Natural Bridge Road, Normandy, MO 63121. All bids should be placed in a sealed envelope with “ATTN: City Clerk, City of Normandy – Public Works Building” written on the envelope.

All questions should be submitted in writing to Brent Boehringer at bboehringer@garlandind.com

Scope of Work

The Scope of Work for the selected respondent shall be consistent with the attached Bid Form, Specification, and Drawings. Submitted bid shall be primarily labor as the following materials will be purchased by the City of Normandy directly, all other materials will be the responsibility of the contractor and should be included in the bid price.

Materials Provided by the City of Normandy:

Product #	Product Name	Unit / Size	Coverage Rate	Quantity
4411-120	StressBase 120	34’8” x 3’3”	100 sq. ft. /	25
7305-5-M	Green-Lock Plus Membrane Adhesive	5GA Pail	2 GA / SQ	10
7306-3-M	Green-Lock Plus Flashing Adhesive	3.5GA Pail	4-6 GA / SQ	5
4365	StressPly FR Mineral	26’2” x 3’3”	75 sq. ft. / roll	35
7110-5	Flashing Bond	5GA Pail	4-6 GA / SQ	5

Selection Criteria

The primary criteria for selection shall be price and the submission of all materials, documents, and bonds as is required in the appendices. However, the City shall also consider other factors such as estimated time of completion, experience, and other characteristics of or facts about the contractor that the City determines is relevant.

The City of Normandy reserves the right to accept or reject all or any part of a submitted proposal, to waive technicalities, and to accept the offer considered to be most advantageous to the City. The City of Normandy also reserves the right to interview, communicate, and negotiate with respondents to the Request for Proposal after sealed bids have been opened.

General Conditions Governing Responses

The following terms and conditions, unless otherwise modified by the City of Normandy within this document, shall govern the submission of proposals and subsequent contracts. The City of Normandy reserves the right to reject any proposal that takes exception to these conditions. The City also reserves the right to reject any and/or all proposals and to select from any or all remaining proposals it believes to be the best for the City, whether or not said proposal is the lowest cost.

Contract

The contract documents used by the City include the RFP, executed Anti-Lobbying and Collusion Statements, and the respondent's Proposal. In the event that conflicts in language exist between the RFP and the proposal, the provisions of the RFP govern. (If the respondent possesses a standard contract, the respondent may supply said contract for review with their proposal).

Assignment or Transfer

Respondents are prohibited from assigning, transferring, conveying, subletting, or otherwise disposing of the proposal or any resultant agreement or its rights, title, or interest, therein or its power to execute such agreement to any other person, company or corporation without the previous written approval of the City.

Indemnification and Hold Harmless

The respondent agrees to indemnify and hold harmless the City of Normandy, Missouri, its agents, officials and employees and to assume all risks, responsibility for death of, injury to or damage to, any person and

for loss, damage or injury to any property (together with all expenses, including attorney fees, in defense or prosecution of any action involving any such death, injury or damage), directly or indirectly related to the performance of this work. The City, or any of its agencies, will not hold harmless or indemnify any respondent for any liability whatsoever.

Compliance with all Government Laws

All contractual agreements shall be subject to, governed by, and construed according to the laws, ordinances, rules, regulations, and orders of the City, County, State, Federal, or any other public bodies, which apply to work performed under this agreement. The City of Normandy is an Equal Opportunity Employer. Every contract undertaken or entered into by the City of Normandy, Missouri, shall comply with the Equal Employment Opportunity regulations.

Enrollment in the Federal Work Authorization Program (E-Verify)

Bidders are informed that pursuant to Section 285.530, RSMo, as a condition of the award of any contract in excess of five thousand dollars (\$5,000.00), the successful bidder shall, by sworn affidavit and provision of documentation, affirm its enrollment and participation in a federal work authorization program with respect to the employees working in connection to the contracted services. Successful bidders shall also sign an affidavit affirming that it does not knowingly employ any person who is an unauthorized alien in connection to the contracted services.

SECTION 07550
MODIFIED BITUMINOUS MEMBRANE ROOFING

PART 1 GENERAL

1.1 SECTION INCLUDES

- A. Cold Applied 2-Ply Solvent Free Asphalt Roofing (StressPly, OptiMax, or VersiPly). (2.5) (3.4)
- B. Accessories. (2.19)
- C. Edge Treatment and Roof Penetration Flashings. (2.20) (3.9)

1.2 SYSTEM DESCRIPTION

Base Bid

1. Remove existing gutter system along with any edge metal.
2. Prep existing roof to ensure a level surface.
3. Mechanically fasten one layer of ½" Dens Deck Prime through existing roof system into the metal deck.
4. Install a 120 mil modified base sheet in cold adhesive.
5. Install a 145 mil modified cap sheet in cold adhesive.
6. Install new gutter system along with any edge metal.

Alternate #1

1. Demo existing roof system down to the metal deck.
2. Remove existing gutter system along with any edge metal.
3. Mechanically fasten 2 layers of 2.75" polyisocyanurate.
4. Mechanically fasten 1 layer of ½" Dens Deck Prime through metal deck.
5. Install a 120 mil modified base sheet in cold adhesive.
6. Install a 145 mil modified cap sheet in cold adhesive.
7. Install a new gutter system along with any edge metal.

1.3 DESIGN / PERFORMANCE REQUIREMENTS

- A. Perform work in accordance with all federal, state and local codes.
- B. Exterior Fire Test Exposure: Roof system shall achieve a UL, FM or WH Class rating for roof slopes indicated on the Drawings as follows:
 1. Factory Mutual Class A Rating.
 2. Underwriters Laboratory Class A Rating.
 3. Warnock Hersey Class A Rating.
- C. Energy Star: Roof System shall comply with the initial and aged reflectivity required by the U.S. Federal Government's Energy Star program.
- D. Roof System membranes containing recycled or bio-based materials shall be third party certified through UL Environment.
 - a.

1.4 SUBMITTALS

- A. Product Data: Manufacturer's data sheets on each product to be used, including:

1. Preparation instructions and recommendations.
 2. Storage and handling requirements and recommendations.
 3. Installation instructions.
- B. Shop Drawings: Submit shop drawings including installation details of roofing, flashing, fastening, insulation and vapor barrier, including notation of roof slopes and fastening patterns of insulation and base modified bitumen membrane, prior to job start.
- C. Design Pressure Calculations: Submit design pressure calculations for the roof area in accordance with ASCE 7 and local Building Code requirements. Include a roof system attachment analysis report, certifying the system's compliance with applicable wind load requirements before Work begins.
- D. Verification Samples: For each modified bituminous membrane ply product specified, two samples, minimum size 6 inches (150 mm) square, representing actual product, color, and patterns.
- E. Manufacturer's Certificates: Provide to certify products meet or exceed specified requirements.
- F. Test Reports: Submit test reports, prepared by an independent testing agency, for all modified bituminous sheet roofing, indicating compliance with ASTM D5147.
- G. Manufacturer's Fire Compliance Certificate: Certify that the roof system furnished is approved by Factory Mutual (FM), Underwriters Laboratories (UL), Warnock Hersey (WH) or approved third party testing facility in accordance with ASTM E108, Class A for external fire and meets local or nationally recognized building codes.
- H. Closeout Submittals: Provide manufacturer's maintenance instructions that include recommendations for periodic inspection and maintenance of all completed roofing work. Provide product warranty executed by the manufacturer. Assist Owner in preparation and submittal of roof installation acceptance certification as may be necessary in connection with fire and extended coverage insurance on roofing and associated work.

1.5 QUALITY ASSURANCE

- A. Perform Work in accordance with NRCA Roofing and Waterproofing Manual.
- B. Manufacturer Qualifications: Company specializing in manufacturing products specified with documented ISO 9001 certification and minimum of twelve years of documented experience and must not have been in Chapter 11 bankruptcy during the last five years.
- C. Installer Qualifications: Company specializing in performing Work of this section with minimum five years documented experience and a certified Pre-Approved Garland Contractor.
- D. Installer's Field Supervision: Maintain a full-time Supervisor/Foreman on job site during all phases of roofing work while roofing work is in progress.
- E. Product Certification: Provide manufacturer's certification that materials are manufactured in the United States and conform to requirements specified herein, are chemically and physically compatible with each other, and are suitable for inclusion within the total roof system specified herein.
- F. Source Limitations: Obtain all components of roof system from a single manufacturer. Secondary products that are required shall be recommended and approved in writing by the roofing system Manufacturer. Upon request of the Architect or Owner, submit Manufacturer's written approval of secondary components in list form, signed by an authorized agent of the

Manufacturer.

1.6 PRE-INSTALLATION MEETINGS

- A. Convene minimum two weeks prior to commencing Work of this section.
- B. Review installation procedures and coordination required with related Work.
- C. Inspect and make notes of job conditions prior to installation:
 1. Record minutes of the conference and provide copies to all parties present.
 2. Identify all outstanding issues in writing designating the responsible party for follow-up action and the timetable for completion.
 3. Installation of roofing system shall not begin until all outstanding issues are resolved to the satisfaction of the Architect.

1.7 DELIVERY, STORAGE, AND HANDLING

- A. Deliver and store products in manufacturer's unopened packaging with labels intact until ready for installation.
- B. Store all roofing materials in a dry place, on pallets or raised platforms, out of direct exposure to the elements until time of application. Store materials at least 4 inches above ground level and covered with "breathable" tarpaulins.
- C. Stored in accordance with the instructions of the manufacturer prior to their application or installation. Store roll goods on end on a clean flat surface except store KEE-Stone FB 60 rolls flat on a clean flat surface. No wet or damaged materials will be used in the application.
- D. Store at room temperature wherever possible, until immediately prior to installing the roll. During winter, store materials in a heated location with a 50 degree F (10 degree C) minimum temperature, removed only as needed for immediate use. Keep materials away from open flame or welding sparks.
- E. Avoid stockpiling of materials on roofs without first obtaining acceptance from the Architect/Engineer.
- F. Adhesive storage shall be between the range of above 50 degree F (10 degree C) and below 80 degree F (27 degree C). Area of storage shall be constructed for flammable storage.

1.8 COORDINATION

- A. Coordinate Work with installing associated metal flashings as work of this section proceeds.

1.9 PROJECT CONDITIONS

- A. Maintain environmental conditions (temperature, humidity, and ventilation) within limits recommended by manufacturer for optimum results. Do not install products under environmental conditions outside manufacturer's absolute limits.

1.10 WARRANTY

- A. Upon completion of the work, provide the Manufacturer's written and signed NDL Warranty, warranting that, if a leak develops in the roof during the term of this warranty, due either to defective material or defective workmanship by the installing contractor, the manufacturer shall provide the Owner, at the Manufacturer's expense, with the labor and material necessary to return the defective area to a watertight condition.
 1. Warranty Period:

- a. 30 years from date of acceptance.

PART 2 PRODUCTS

2.1 MANUFACTURERS

- A. Acceptable Manufacturer: Garland Company, Inc. (The), which is located at: 3800 E. 91st St.; Cleveland, OH 44105; Toll Free Tel: 800-321-9336; Tel: 216-641-7500; Fax: 216-641-0633; Email:[request info \(\)](mailto:request info ()); Web:<http://www.garlandco.com>
- B. The City of Normandy is using the Omnia Partners Government Purchasing Alliance program for Roofing Supplies and Related Products and Services, as priced by and awarded to Garland/DBS, Inc., resulting from the competitively solicited Sealed Bid # PW1925 issued by the Racine County. The roofing installer is responsible for supplying the right quantity of these roofing materials to complete the **(Public Works Building)** as detailed in this specification and is responsible for obtaining any additional materials that are required to properly install the specified roofing systems at no additional charge to the Owner. All materials needed to complete this project that are not listed on the OMNIA Partners Government Purchasing List of Materials attachment provided in this specification, but that are required in this specification, must be supplied by the roofing installer and meet stated performance specification listed in this document.
- C. Product Description(s) and Quantities Listed Below:
 - 1. All materials listed below to be purchased directly by the City of Normandy.
 - 2. All other materials are the responsibility of the contractor and should be included in your bid price.

Product #	Product Name	Unit / Size	Coverage Rate	Quantity
4411-120	StressBase 120	34'8" x 3'3"	100 sq. ft. /	25
7305-5-M	Green-Lock Plus Membrane Adhesive	5GA Pail	2 GA / SQ	10
7306-3-M	Green-Lock Plus Flashing Adhesive	3.5GA Pail	4-6 GA / SQ	5
4365	StressPly FR Mineral	26'2" x 3'3"	75 sq. ft. / roll	35
7110-5	Flashing Bond	5GA Pail	4-6 GA / SQ	5

2.2 COLD APPLIED 2-PLY ASPHALT ROOFING - STRESSPLY, OPTIMAX, OR VERSIPLY

- A. Base (Ply) Sheet: One ply bonded to the prepared substrate with Interply Adhesive:
 - 1. StressBase 120:
- B. Modified Cap (Ply) Sheet: One ply bonded to the prepared substrate with Interply Adhesive.
 - 1. StressPly FR Mineral:
- C. Interply Adhesive: (Layer 1 and 2)
 - 1. Green-Lock Plus Membrane Adhesive

- D. Flashing Base Ply: One ply bonded to the prepared substrate with Interply Adhesive: except torch sheet.
 - 1. StressBase 120:
- E. Flashing Cap (Ply) Sheet: One ply bonded to the prepared substrate with Interply Adhesive: except torch sheet.
 - 1. StressPly FR Mineral:
- F. Flashing Ply Adhesive:
 - 1. Green-Lock Plus Flashing Adhesive

2.3 ACCESSORIES:

- A. Roof Insulation: In accordance with Section 07220.
- B. Roof Insulation: Provide G-P Gypsum DenDeck Prime, G-P Gypsum DenDeck DuraGuard, USG Securrock for proper adhesion of the self-adhered base sheet in accordance with Section 07220.

PART 3 EXECUTION

3.1 EXAMINATION

- A. Do not begin installation until substrates have been properly prepared.
- B. Inspect and approve the deck condition, slopes and fastener backing if applicable, parapet walls, expansion joints, roof drains, stack vents, vent outlets, nailers and surfaces and elements.
- C. Verify that work penetrating the roof deck, or which may otherwise affect the roofing, has been properly completed.
- D. If substrate preparation and other conditions are the responsibility of another installer, notify Architect of unsatisfactory preparation before proceeding.

3.2 PREPARATION

- A. General: Clean surfaces thoroughly prior to installation.
 - 1. Prepare surfaces using the methods recommended by the manufacturer for achieving the best result for the substrate under the project conditions.
 - 2. Fill substrate surface voids that are greater than 1/4 inch wide with an acceptable fill material.
 - 3. Roof surface to receive roofing system shall be smooth, clean, free from loose gravel, dirt and debris, dry and structurally sound.
 - 4. Wherever necessary, all surfaces to receive roofing materials shall be power broom and vacuumed to remove debris and loose matter prior to starting work.
 - 5. Do not apply roofing during inclement weather. Do not apply roofing membrane to damp, frozen, dirty, or dusty surfaces.
 - 6. Fasteners and plates for fastening components mechanically to the substrate shall provide a minimum pull-out capacity of 300 lbs. (136 k) per fastener. Base or ply sheets attached with cap nails require a minimum pullout capacity of 40 lb. per nail.
 - 7. Prime decks where required, in accordance with requirements and recommendations of the primer and deck manufacturer.
- B. Metal Deck: Metal deck shall be installed as specified in Section
 - 1. Fastening of the deck should comply with the anticipated live and dead loads pertaining to the building as well as applicable Code.
 - 2. Steel decks shall be minimum 22-gauge factory galvanized or zinc alloy coated for

protection against corrosion.

3. Suitable insulation shall be mechanically attached as recommended by the insulation manufacturer.
4. Decks shall comply with the gauge and span requirements in the current Factory Mutual FM Approval Guide and be installed in accordance with Loss Prevention Data Sheet 1-28 or specific FM approval.
5. When re-roofing over steel decks, surface corrosion shall be removed, and repairs to severely corroded areas made. Loose or inadequately secured decking shall be fastened, and irreparable or otherwise defective decking shall be replaced.

3.3 INSTALLATION - GENERAL

- A. Install modified bitumen membranes and flashings in accordance with manufacturer's instructions and with the recommendations provided by the National Roofing Contractors Association's Roofing & Waterproofing Manual, the Asphalt Roofing Manufacturers Association, and applicable codes.
- B. General: Avoid installation of modified bitumen membranes at temperatures lower than 40-45 degrees F. When work at such temperatures unavoidable use the following precautions:
 1. Take extra care during cold weather installation and when ambient temperatures are affected by wind or humidity, to ensure adequate bonding is achieved between the surfaces to be joined. Use extra care at material seam welds and where adhesion of the applied product to the appropriately prepared substrate as the substrate can be affected by such temperature constraints as well.
 2. Unrolling of cold materials, under low ambient conditions must be avoided to prevent the likelihood of unnecessary stress cracking. Rolls must be at least 40 degrees F at the time of application. If the membrane roll becomes stiff or difficult to install, it must be replaced with roll from a heated storage area.
- C. Commence installation of the roofing system at the lowest point of the roof (or roof area), working up the slope toward the highest point. Lap sheets shingle fashion so as to constantly shed water
- D. All slopes greater than 2:12 require back-nailing to prevent slippage of the ply sheets. Use ring or spiral-shank 1 inch cap nails, or screws and plates at a rate of 1 fastener per ply (including the membrane) at each insulation stop. Place insulation stops at 16 ft o.c. for slopes less than 3:12 and 4 feet o.c. for slopes greater than 3:12. On non-insulated systems, nail each ply directly into the deck at the rate specified above. When slope exceeds 2:12, install all plies parallel to the slope (strapping) to facilitate backnailing. Install 4 additional fasteners at the upper edge of the membrane when strapping the plies.

3.4 INSTALLATION COLD APPLIED ROOF SYSTEM

- A. Base Ply: Cut base ply sheets to 18 foot lengths and allow plies to relax before installing. Install base sheet in Interply Adhesive: applied at the rate required by the manufacturer. Shingle base sheets uniformly to achieve one ply throughout over the prepared substrate. Shingle in proper direction to shed water on each large area of roofing.
 1. Lap ply sheet ends 8 inches. Stagger end laps 12 inches minimum.
 2. Solidly bond to the substrate and adjacent ply with specified cold adhesive at the rate of 2 to 2-1/2 gallons per 100 square feet.
 3. Roll must push a puddle of adhesive in front of it with adhesive slightly visible at all side laps. Use care to eliminate air entrapment under the membrane.
 4. Install subsequent rolls of modified across the roof as above with a minimum of 4 inch side laps and 8 inch staggered end laps. Lay modified membrane in the same direction as the underlayers but the laps shall not coincide with the laps of the base layers.
 5. Extend plies 2 inches beyond top edges of cants at wall and projection bases.

6. Install base flashing ply to all perimeter and projection details.
 7. Allow the one ply of base sheet to cure at least 30 minutes before installing the modified membrane. However, the modified membrane must be installed the same day as the base plies.
- B. Modified Cap Ply(s): Cut cap ply sheets into 18 foot lengths and allow plies to relax before installing. Install in interply adhesive applied at the rate required by the manufacturer. Shingle sheets uniformly over the prepared substrate to achieve the number of plies specified. Shingle in proper direction to shed water on each large area of roofing.
1. Lap ply sheet ends 8 inches. Stagger end laps 12 inches minimum.
 2. Solidly bond to the base layers with specified cold adhesive at the rate of 2 to 2-1/2 gallons per 100 square feet.
 3. Roll must push a puddle of adhesive in front of it with adhesive slightly visible at all side laps. Care should be taken to eliminate air entrapment under the membrane.
 4. Install subsequent rolls of modified across the roof as above with a minimum of 4 inch side laps and 8 inch staggered end laps. Lay modified membrane in the same direction as the underlayers but the laps shall not coincide with the laps of the base layers.
 5. Allow cold adhesive to set for 5 to 10 minutes before installing the top layer of modified membrane.
 6. Extend membrane 2 inches beyond top edge of all cants in full moppings of the cold adhesive as shown on the drawings.
- C. Fibrous Cant Strips: Provide non-combustible perlite or glass fiber cant strips at all wall/curb detail treatments where angle changes are greater than 45 degrees. Cant may be set in approved cold adhesives, hot asphalt or mechanically attached with approved plates and fasteners.
- D. Wood Blocking, Nailers and Cant Strips: Provide wood blocking, nailers and cant strips as specified in Section 06114.
1. Provide nailers at all roof perimeters and penetrations for fastening membrane flashings and sheet metal components.
 2. Wood nailers should match the height of any insulation, providing a smooth and even transition between flashing and insulation areas.
 3. Nailer lengths should be spaced with a minimum 1/8 inch gap for expansion and contraction between each length or change of direction.
 4. Nailers and flashings should be fastened in accordance with Factory Mutual "Loss Prevention Data Sheet 1- 49, Perimeter Flashing" and be designed to be capable of resisting a minimum force of 200 lbs/lineal foot in any direction.
- E. Metal Work: Provide metal flashings, counter flashings, parapet coping caps and thru-wall flashings as specified in Section 07620 or Section 07710. Install in accordance with the SMACNA "Architectural Sheet Metal Manual" or the NRCA Roofing Waterproofing manual.
- F. Termination Bar: Provide a metal termination bar or approved top edge securement at the terminus of all flashing sheets at walls and curbs. Fasten the bar a minimum of 8 inches (203 mm) o/c to achieve constant compression. Provide suitable, sealant at the top edge if required.
- G. Flashing Base Ply: Install flashing sheets by the same application method used for the base ply.
1. Seal curb, wall and parapet flashings with an application of mastic and mesh on a daily basis. Do not permit conditions to exist that will allow moisture to enter behind, around or under the roof or flashing membrane.
 2. Prepare all walls, penetrations, expansion joints and surfaces to be flashed with required primer at the rate of 100 square feet per gallon. Allow primer to dry tack free.
 3. Adhere to the underlying base flashing ply with specified hot material unless otherwise

noted in these specifications. Nail off at a minimum of 8 inches (203 mm) o.c. from the finished roof at all vertical surfaces.

4. Solidly adhere the entire sheet of flashing membrane to the substrate.
 5. Seal all vertical laps of flashing membrane with a three-course application of trowel-grade mastic and mesh.
 6. Coordinate counter flashing, cap flashings, expansion joints, and similar work with modified bitumen roofing work as specified.
 7. Coordinate roof accessories, miscellaneous sheet metal accessory items, including piping vents and other devices with the roofing system work.
- H. Flashing Cap Ply: Install flashing cap sheets by the same application method used for the cap ply.
1. Seal curb, wall and parapet flashings with an application of mastic and mesh on a daily basis. Do not permit conditions to exist that will allow moisture to enter behind, around or under the roof or flashing membrane.
 2. Prepare all walls, penetrations, expansion joints and where shown on the Drawings to be flashed with required primer at the rate of 100 square feet per gallon. Allow primer to dry tack free.
 3. Adhere to the underlying base flashing ply with specified flashing ply adhesive unless otherwise specified. Nail off at a minimum of 8 inches (203 mm) o.c. from the finished roof at all vertical surfaces.
 4. Coordinate counter flashing, cap flashings, expansion joints and similar work with modified bitumen roofing work as specified.
 5. Coordinate roof accessories, miscellaneous sheet metal accessory items with the roofing system work.
 6. All stripping shall be installed prior to flashing cap sheet installation.
 7. Heat and scrape granules when welding or adhering at cut areas and seams to granular surfaces at all flashings.
 8. Secure the top edge of the flashing sheet using a termination bar only when the wall surface above is waterproofed, or nailed 4 inches on center and covered with an acceptable counter flashing.
- I. Roof Walkways: Provide walkways in areas indicated on the Drawings.

3.5 CLEANING

- A. Clean-up and remove daily from the site all wrappings, empty containers, paper, loose particles and other debris resulting from these operations.
- B. Remove asphalt markings from finished surfaces.
- C. Repair or replace defaced or disfigured finishes caused by Work of this section.

3.6 PROTECTION

- A. Provide traffic ways, erect barriers, fences, guards, rails, enclosures, chutes and the like to protect personnel, roofs and structures, vehicles and utilities.
- B. Protect exposed surfaces of finished walls with tarps to prevent damage.
- C. Plywood for traffic ways required for material movement over existing roofs shall be not less than 5/8 inch (16 mm) thick.
- D. In addition to the plywood listed above, an underlayment of minimum 1/2 inch (13 mm) recover board is required on new roofing.

- E. Special permission shall be obtained from the Manufacturer before any traffic shall be permitted over new roofing.

3.7 FIELD QUALITY CONTROL

- A. Inspection: Provide manufacturer's field observations at least 3 times per week. Provide detailed reports to the owner immediately following each site visit. Provide a final inspection upon completion of the Work.
1. Warranty shall be issued upon manufacturer's acceptance of the installation.
 2. Field observations shall be performed by a Sales Representative employed full-time by the manufacturer and whose primary job description is to assist, inspect and approve membrane installations for the manufacturer.
 3. Provide observation reports from the Sales Representative indicating procedures followed, weather conditions and any discrepancies found during inspection.
 4. Provide a final report from the Sales Representative, certifying that the roofing system has been satisfactorily installed according to the project specifications, approved details and good general roofing practice.

3.8 SCHEDULES

- A. Base (Ply) Sheet:
1. StressBase 120: 120 mil SBS (Styrene-Butadiene-Styrene) rubber modified roofing base sheet with dual fiberglass reinforced scrim, performance requirements according to ASTM D 5147.
 - a. Tensile Strength, ASTM D 5147
 - 1) 2 in/min. @ 0 +/- 3.6 deg. F MD 100 lbf/in XD 100 lbf/in
 - 2) 50mm/min. @ -17.78 +/- 2 deg. C MD 17.5 kN/m XD 17.5 kN/m
 - b. Tear Strength, ASTM D 5147
 - 1) 2 in/min. @ 73.4 +/- 3.6 deg. F MD 100 lbf XD 85 lbf
 - 2) 50mm/min. @ 23 +/- 2 deg. C MD 444 N XD 378 N
 - c. Elongation at Maximum Tensile, ASTM D 5147
 - 1) 2 in/min. @ 0 +/- 3.6 deg. F MD 4 % XD 4 %
 - 2) 50mm/min @ -17.78 +/- 2 deg. C MD 4 % XD 4 %
 - d. Low Temperature Flexibility, ASTM D 5147, Passes -40 deg. F (-40 deg. C)
- B. Thermoplastic/Modified Cap (Ply) Sheet:
1. StressPly FR Mineral: 145 mil SBS (Styrene-Butadiene-Styrene) rubber modified roofing membrane with dual fiberglass reinforced scrim and superior low temperature capabilities. ASTM D 6163, Type III Grade S
 - a. Tensile Strength, ASTM D 5147
 - 1) 2 in/min. @ 73.4 +/- 3.6 deg. F MD 225 lbf/in XD 225 lbf/in
 - 2) 50 mm/min. @ 23 +/- 2 deg. C MD 39.0 kN/m XD 39 kN/m
 - b. Tear Strength, ASTM D 5147
 - 1) 2 in/min. @ 73.4 +/- 3.6 deg. F MD 300 lbf XD 300 lbf
 - 2) 50 mm/min. @ 23 +/- 2 deg. C MD 1335 N XD 1335 N
 - c. Elongation at Maximum Tensile, ASTM D 5147
 - 1) 2 in/min. @ 73.4 +/- 3.6 deg. F MD 6% XD 8%
 - 2) 50 mm/min. @ 23 +/- 2 deg. C MD 6% XD 8%
 - d. Low Temperature Flexibility, ASTM D 5147, Passes -30 deg. F (-34.4 deg. C)
- C. Interply Adhesive:
1. Green-Lock Plus Membrane Adhesive: Cold applied solvent free membrane adhesive: zero V.O.C. compliant performance requirements:
 - a. Non-Volatile Content ASTM D 4586 100%
 - b. Density ASTM D 1475 12.3 lbs./gal. (1.47 g/cm³)
 - c. Viscosity Brookfield Spindle T-E at 5 rpm 124,000 cPs.
 - d. Flash Point ASTM D 93 400 deg. F min. (232 deg. C)

- e. Slope: up to 3:12
- D. Flashing Base Ply:
1. StressBase 120: 120 mil SBS (Styrene-Butadiene-Styrene) rubber modified roofing base sheet with dual fiberglass reinforced scrim, performance requirements according to ASTM D 5147.
 - a. Tensile Strength, ASTM D 5147
 - 1) 2 in/min. @ 0 +/- 3.6 deg. F MD 100 lbf/in XD 100 lbf/in
 - 2) 50mm/min. @ -17.78 +/- 2 deg. C MD 17.5 kN/m XD 17.5 kN/m
 - b. Tear Strength, ASTM D 5147
 - 1) 2 in/min. @ 73.4 +/- 3.6 deg. F MD 100 lbf XD 85 lbf
 - 2) 50mm/min. @ 23 +/- 2 deg. C MD 444 N XD 378 N
 - c. Elongation at Maximum Tensile, ASTM D 5147
 - 1) 2 in/min. @ 0 +/- 3.6 deg. F MD 4 % XD 4 %
 - 2) 50 mm/min. @ -17.78 +/- 2 deg. C MD 4 % XD 4 %
 - d. Low Temperature Flexibility, ASTM D 5147
 - 1) Passes -40 deg. F (-40 deg. C)
- E. Flashing Ply Adhesive:
1. Flashing Bond: Asphalt roofing mastic V.O.C. compliant, ASTM D 4586, Type II trowel grade flashing adhesive.
 - a. Non-Volatile Content ASTM D 4479 70 min.
 - b. Density ASTM D 1475 8.3 lbs./gal. (1kg/l)
 - c. Flash Point ASTM D 93 103 deg. F (39 deg. C)
- F. Surfacing:
1. Flashing Cap (Ply) Sheet:
 - a. StressPly FR Mineral: 145 mil SBS (Styrene-Butadiene-Styrene) rubber modified roofing membrane with dual fiberglass reinforced scrim and superior low temperature capabilities. ASTM D 6163, Type III Grade S
 - 1) Tensile Strength, ASTM D 5147
 - a) 2 in/min. @ 73.4 +/- 3.6 deg. F MD 225 lbf/in XD 225 lbf/in
 - b) 50 mm/min. @ 23 +/- 2 deg. C MD 39.0 kN/m XD 39 kN/m
 - 2) Tear Strength, ASTM D 5147
 - a) 2 in/min. @ 73.4 +/- 3.6 deg. F MD 300 lbf XD 300 lbf
 - b) 50 mm/min. @ 23 +/- 2 deg. C MD 1335 N XD 1335 N
 - 3) Elongation at Maximum Tensile, ASTM D 5147
 - a) 2 in/min. @ 73.4 +/- 3.6 deg. F MD 6% XD 8%
 - b) 50 mm/min. @ 23 +/- 2 deg. C MD 6% XD 8%
 - 4) Low Temperature Flexibility, ASTM D 5147, Passes -30 deg. F (-34.4 deg. C)

END OF SECTION

NORMANDY PUBLIC WORKS BUILDING

5800 BERMUDA DRIVE, NORMANDY, MO



RFP: City of Normandy Public Works Roof

LOCATION MAP

5800 BERMUDA DRIVE
NORMANDY, MO 63121



KEY PLAN

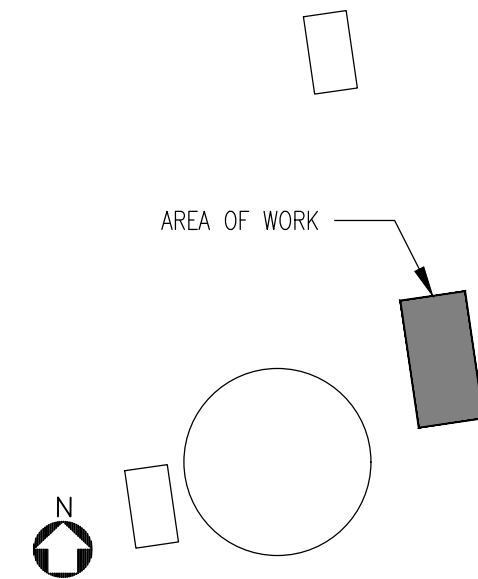

DRAWING INDEX

- SHT 1 - COVER SHEET
- SHT 2 - ROOF PLAN
- SHT 3 - DETAILS
- SHT 4 - DETAILS

THE GARLAND COMPANY INC.
3800 EAST 91st STREET - CLEVELAND, OHIO 44105-2197
PHONE (800) 327-9336 / FAX (216) 641-0633



NORMANDY PUBLIC WORKS BUILDING
5800 BERMUDA DRIVE, NORMANDY, MO

AGENT: BRENT BEHRINGER
JOB NUMBER: DWG BY: GCK CHK BY:

ARCHITECT: CUSTOMER:

DATE: 09-15-22

SHEET: 1 OF 4

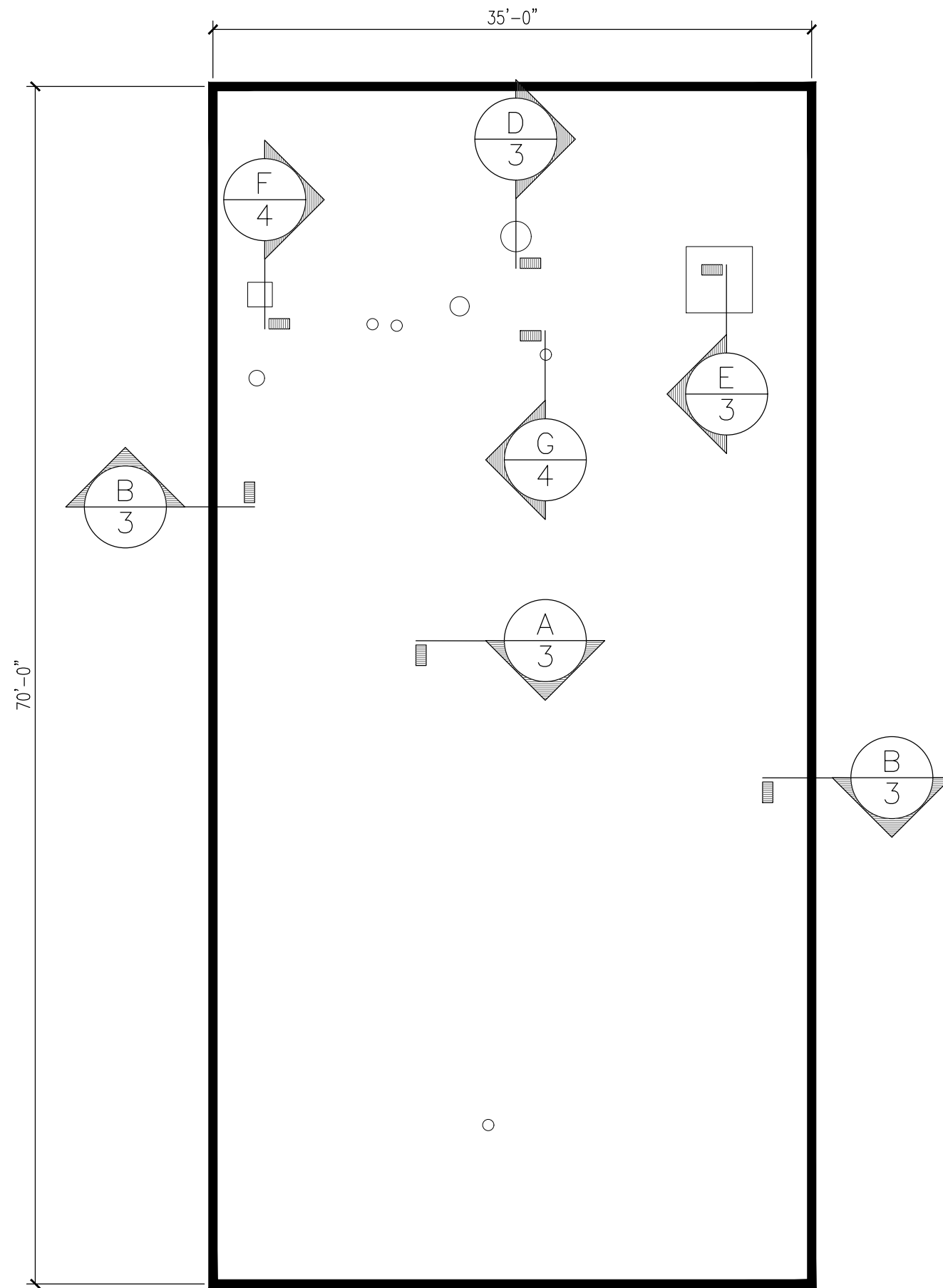

SCOPE OF WORK:

BASE BID

1. REMOVE EXISTING GUTTER SYSTEM ALONG WITH ANY EDGE METAL.
2. PREP EXISTING ROOF TO ENSURE A LEVEL SURFACE.
3. MECHANICALLY FASTEN ONE LAYER OF 1/2" DENS DECK PRIME THROUGH THE EXISTING ROOF SYSTEM INTO THE METAL DECK.
4. INSTALL A 120 MIL MODIFIED BASE SHEET IN COLD ADHESIVE.
5. INSTALL A 145 MIL MODIFIED CAP SHEET IN COLD ADHESIVE.
6. INSTALL NEW GUTTER SYSTEM ALONG WITH ANY EDGE METAL.

ALTERNATE #1

1. DEMO EXISTING ROOF SYSTEM DOWN TO THE METAL DECK.
2. REMOVE EXISTING GUTTER SYSTEM ALONG WITH ANY EDGE METAL.
3. MECHANICALLY FASTEN POLYISOCYANURATE TO MEET R30 REGULATION.
4. MECHANICALLY FASTEN ONE LAYER OF 1/2" DENS DECK PRIME THROUGH INSULATION INTO THE METAL DECK.
5. INSTALL A 120 MIL MODIFIED BASE SHEET IN COLD ADHESIVE.
6. INSTALL A 145 MIL MODIFIED CAP SHEET IN COLD ADHESIVE.
7. INSTALL NEW GUTTER SYSTEM ALONG WITH ANY EDGE METAL.

ROOF PLAN
SCALE: 1/8" = 1'-0"



THE GARLAND COMPANY INC.
3800 EAST 91st STREET - CLEVELAND, OHIO 44105-2197
PHONE (800) 327-9356 / FAX (216) 641-0633



NORMANDY PUBLIC WORKS BUILDING 5000 BERUDA DRIVE, NORMANDY, MO		AGENT: BRENT BEHRINGER	DWG BY: GCK	CHK BY:
ARCHITECT:	CUSTOMER:	DATE: 09-15-22	OF 4	
REVISION:			2	
				SHEET: 16

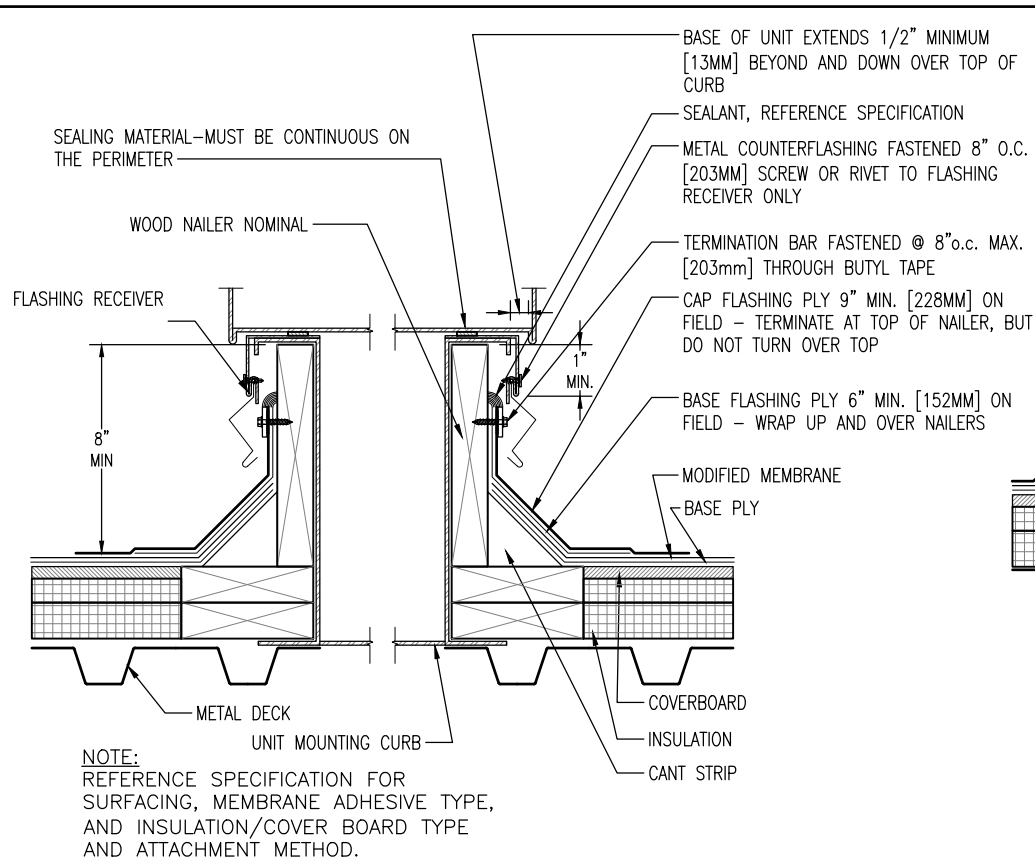

E
3
CURB DETAIL / AIR HANDLING STATION
SCALE: 1/2" = 1'-0"

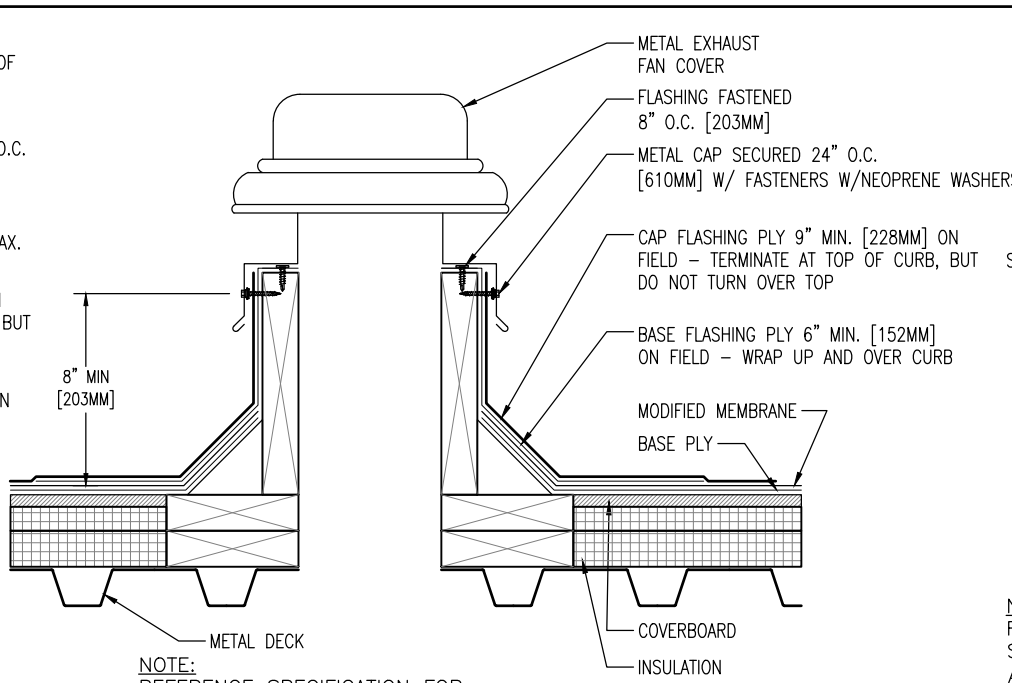

D
3
EXHAUST FAN
SCALE: 1/2" = 1'-0"

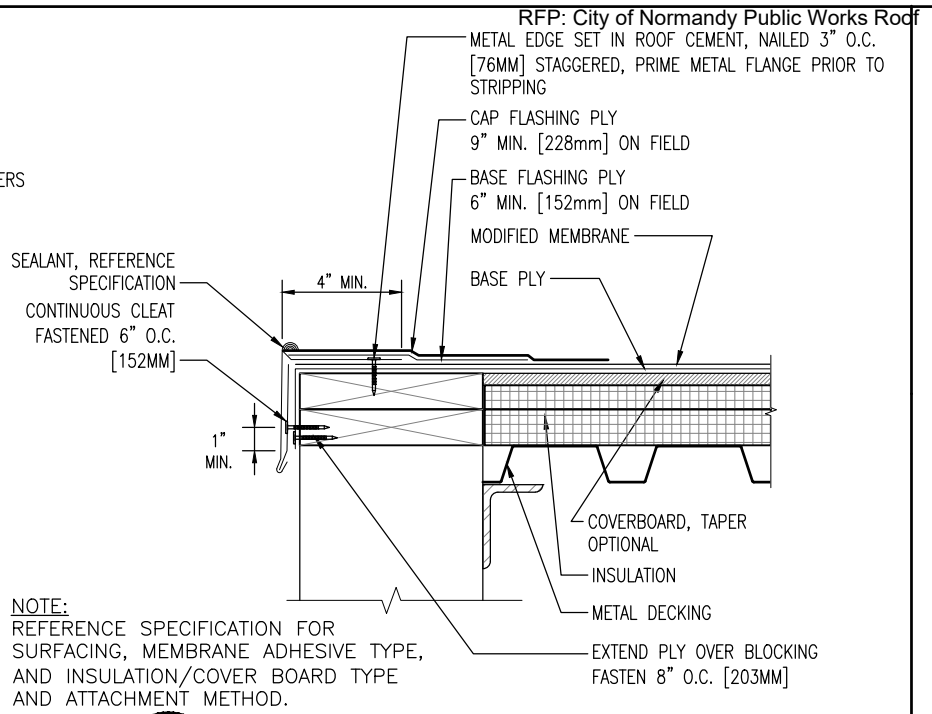

C
3
METAL EDGE - DRIP EDGE
SCALE: 1/2" = 1'-0"

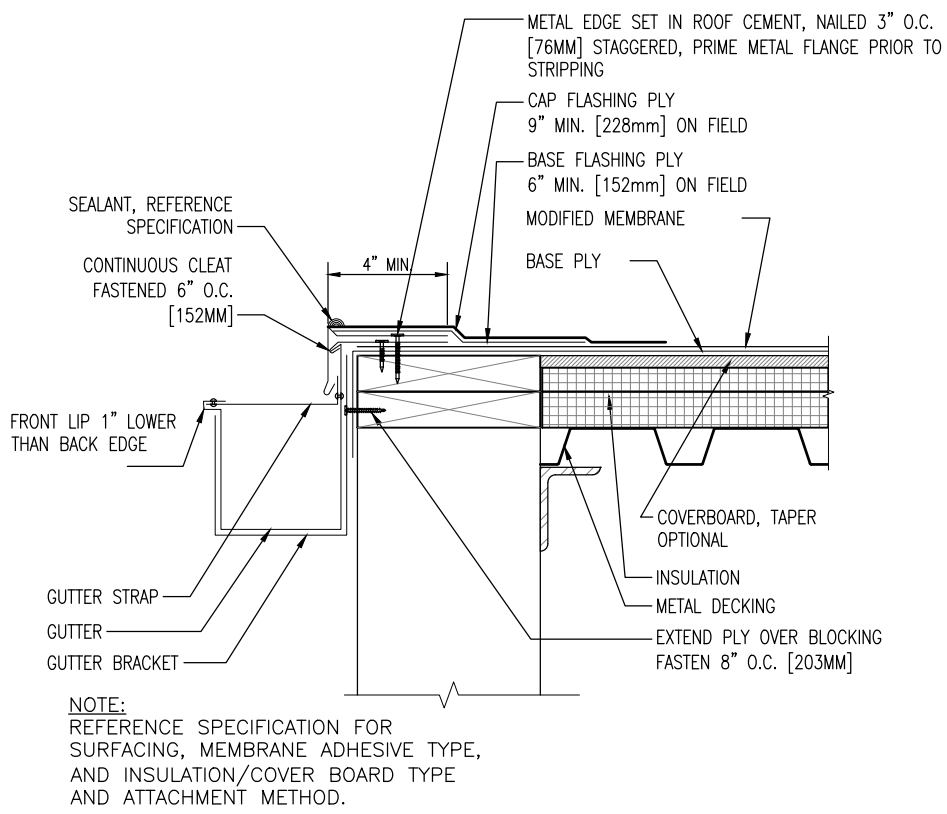

B
3
METAL EDGE - DRIP EDGE WITH GUTTER
SCALE: 1/2" = 1'-0"

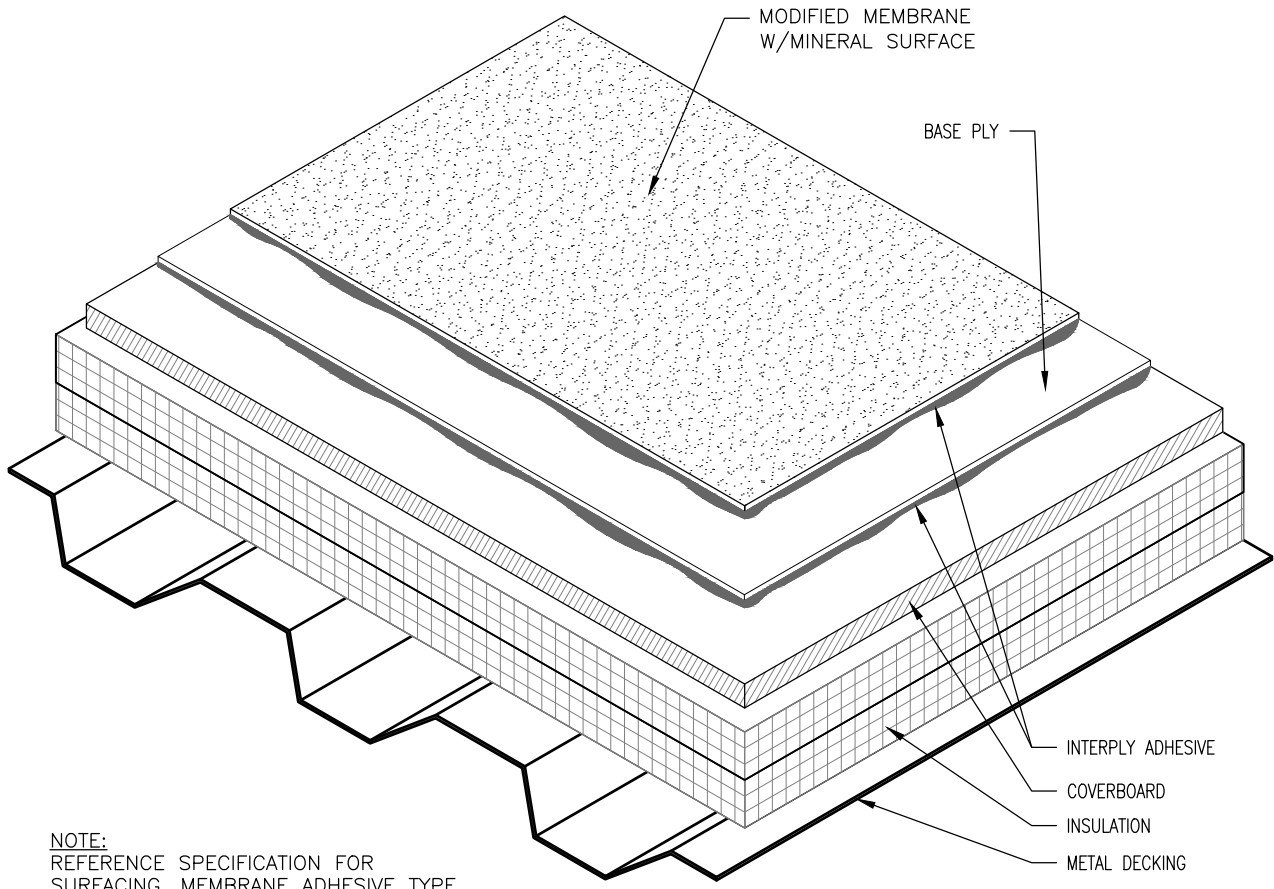

A
3
TYPICAL ROOF SYSTEM MINERAL SURFACE
SCALE: 3" = 1'-0"

RFP: City of Normandy Public Works Roof

3800 EAST 91st STREET - CLEVELAND, OHIO 44105-2197
PHONE (800) 321-9356 / FAX (216) 641-0633

THE GARLAND COMPANY INC.

NORMANDY PUBLIC WORKS BUILDING
5800 BERNUDA DRIVE, NORMANDY, MO

AGENT: BRENT EBERHART
JOB NUMBER:

CHK BY: GCK
DWG BY: GCK

ARCHITECT:

CUSTOMER:

DATE: 09-15-22

SHEET: 3 OF 4

REVISION:

THE GARLAND COMPANY INC.
 3800 EAST 91st STREET - CLEVELAND, OHIO 44105-2197
 PHONE (800) 327-9336 / FAX (216) 641-0633



NORMANDY PUBLIC WORKS BUILDING
 5800 BERMUDA DRIVE, NORMANDY, MO

AGENT: BRENT BEHRINGER
 JOB NUMBER:

ARCHITECT:
 CUSTOMER:

DATE: 09-15-22

REVISION:
 SHEET: 4 OF 4

CHK BY:

DWG BY: GCK

JOB NUMBER:

CUSTOMER:

DATE: 09-15-22

SHEET: 4 OF 4

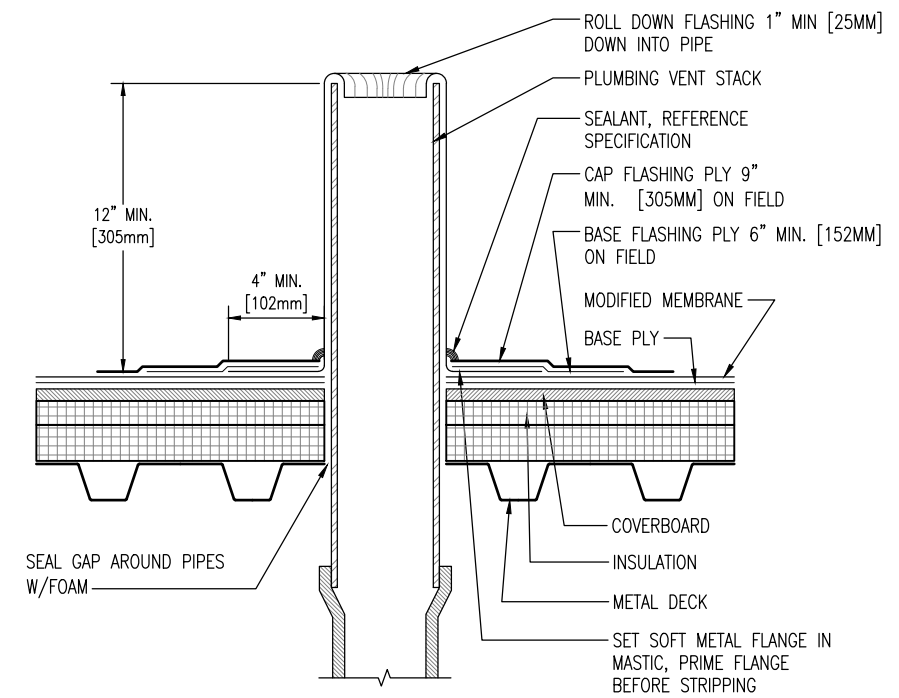

NOTE:
 REFERENCE SPECIFICATION FOR
 SURFACING, MEMBRANE ADHESIVE TYPE,
 AND INSULATION/COVER BOARD TYPE
 AND ATTACHMENT METHOD.

G PLUMBING STACK
 SCALE: 1/2" = 1'-0"

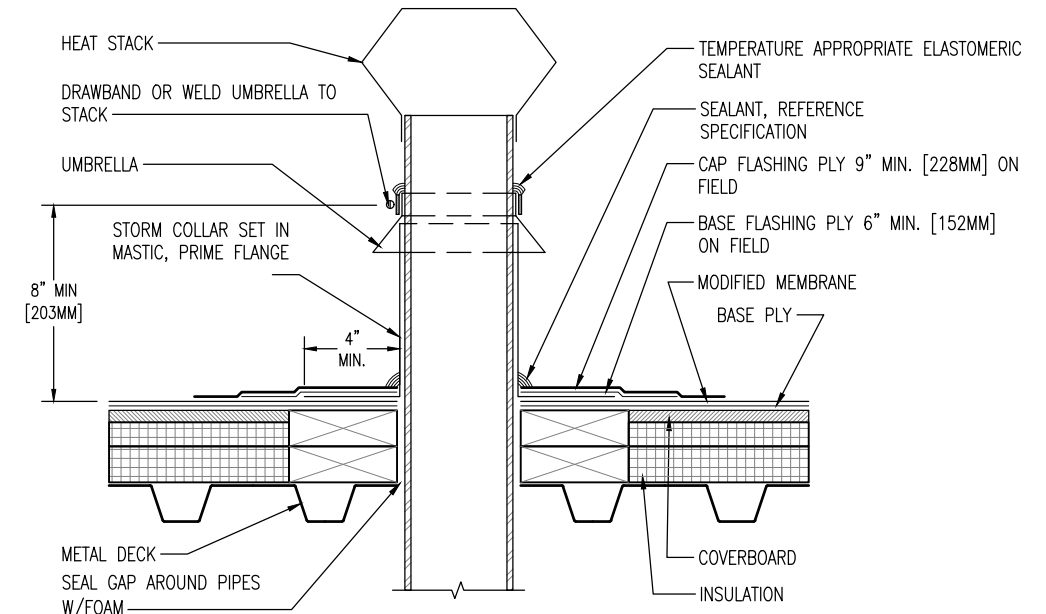

NOTE:
 REFERENCE SPECIFICATION FOR
 SURFACING, MEMBRANE ADHESIVE TYPE,
 AND INSULATION/COVER BOARD TYPE
 AND ATTACHMENT METHOD.

F HEAT STACK
 SCALE: 1/2" = 1'-0"

BID FORM

PROJECT: City of Normandy – Public Works Building

PLACE: 5800 Bermuda Drive, Normandy, MO 63121

MANDATORY PREBID SITE VISIT TIME: 11/09/22 @ 1130am - Normandy Public Works Building

SEALED BIDS DUE & BID OPENING: 11/15/22 @ 10:00am

BID LOCATION: 7700 Natural Bridge Road, St. Louis, MO 63121

SEALED BIDS MARKED: “City of Normandy – Public Works Building”

NOTE: Please contact Brent Boehringer (314-210-5870) for questions pertaining to the project.

1. Pursuant to and in compliance with the Invitation to Bid and the, relating to the above referenced project, the undersigned, hereby proposes and agrees to fully perform the work within the time stated and in strict accordance with the proposed Contract Documents, and Addenda thereto, for the following sum of money:

- 1. Normandy Public Works Building: Modified Bitumen (Retrofit)

All labor, materials, services, and equipment necessary for completion of the work shown on the drawings as Base Bid.

_____ DOLLARS (\$_____)

- 2. Normandy Public Works Building: Modified Bitumen (Tear off/Re-Roof)

All labor, materials, services, and equipment necessary for completion of the work shown on the drawings as Alternate #1.

_____ DOLLARS (\$_____)

2. The undersigned will execute a satisfactory Construction Contract and proof of insurance coverage, with the Owner for the entire work as per the Contract Documents within 10 days after notice of award. It is agreed that this proposal is subject to the Owners acceptance for a period of thirty (30) days from the above date. The City of Normandy is exempt

from all local, state, and federal taxes. Successful Bidder must complete a W-9 form (Taxpayer Identification No.).

3. UNIT PRICES: The undersigned agrees, in case of variation of quantities from those shown or specified, the following unit prices will be used in adjusting the Contract price. If additional quantities are authorized in advance by the Owner. The following amount will be added to the Contract:

- 1. Cost per square foot to repair existing corrugated metal deck: \$_____
- 2. Cost per square foot to replace existing wet polyisocyanurate: \$_____

3. The undersigned agrees to the following:

- 1. To furnish all labor and materials as shown and specified.
- 2. To complete Bid Item #1 in _____ calendar days.
- 3. To work _____ working days per week.
- 4. To begin work _____ days after notice of award of contract.

4. Receipt is acknowledged of the following addenda:

No. _____ Dated _____

5. MISSOURI WAGE AND LABOR STANDARDS & FEDERAL DAVIS-BACON ACT
Not less than the prevailing hourly wages, as determined by the State of Missouri, Division of Labor Standards and Davis Bacon Act shall be paid all workers employed on a project of \$75,000 or more.

It is the statutory policy of the State of Missouri “that a wage of no less than the prevailing hourly rate of wages for work of a similar character in the locality in which the work is performed, shall be paid to all workmen employed by or on behalf of any public body engaging in public works exclusive of maintenance work.” Section 290.290.RSMo.

- a) The prevailing hourly rate of wages in this locality for each type of workman needed to execute the contract and also the general prevailing rate for legal holiday and overtime work, all as determined by the Division of Labor Standards.
- b) The Contractor shall forfeit as a penalty to the Owner on whose behalf the contract is awarded, \$100 per day for each workman employed for each calendar day, or portion

thereof, such workman is paid less than the said stipulated rates for any work done under said contract, by him or any subcontractor under him.

- c) Contractor's bonds shall include such provisions as will guarantee the faithful performance of the prevailing wage clause as provided by contract.
- d) Contractor records shall be inspected periodically and when complaints are made pertaining to the wage paid all workmen employed in the construction of the public works.
- e) All contractors and each subcontractor engaged in any work shall submit certified copies of their weekly payrolls to the contracting body for work performed on the project.
- f) The Contractor and all subcontractors to the contract must require all on-site employees to complete the ten-hour safety training program required under Section 292.675, RSMo, if they have not previously completed the program and have documentation of doing so. The contractor will forfeit a penalty to the contracting public body of \$2500 plus an additional \$100 for each employee employed by the contractor or subcontractor, for each calendar day, or portion thereof, such employee is employed without the required training.
- g) During periods of excessive unemployment only Missouri laborers and laborers from non-restrictive states may be employed under the contract. (see sections 290.550 through 290.580, RSMo.)
- h) Before final payment is made on the contract an affidavit must be filed by the contractor stating that he has fully complied with the prevailing wage law.
- i) Bids must be accompanied by Bid Security in the form of a cashier's check, certified check or Bid Bond in an amount not less than five percent of the bid.
- j) Contractors bidding on a contract for services in excess of \$5,000 to provide a sworn affidavit and supporting documentation that affirms the contractor's participation in a federal work authorization program, such as E-Verify, and that the bidder will not employ illegal workers for the project. A contractor is only required to provide this affidavit to the City annually.
- k) Before work begins, 'transient employers' (as defined in section 285.230, RSMo.) must file a financial assurance instrument with the director of revenue and provide proof of compliance to the district or otherwise provide financial security to the district as required by law. Once work begins, a transient employer must post in a prominent and easily accessible place at the worksite a clearly legible copy of :
 - i. The notice of registration for employer withholding issued to the transient employer by the director of revenue.
 - ii. Proof of coverage for workers' compensation insurance or self-insurance signed by the transient employer and verified by the Department of Revenue through the records of the Division of Workers' Compensation.
 - iii. The notice of registration for unemployment security.
 - iv. Any transient employer failing to comply with these requirements will be liable for a penalty of \$500 per day until the notices required are posted as required by statute. Contractors utilizing transient employers as subcontractors are required to ensure that the subcontractors are complying with state statute.
- l) Contractors and subcontractors are required to report to the district the date and amount of any wage subsidy, bid supplement or rebate for employment on a public works project received within 30 calendar days of receipt of payment, as required by state law. Such subsidies, supplements or rebates are prohibited if they reduce the wage rate below the

prevailing wage rate. Contractors and subcontractors who do not comply will owe the district a penalty as required by law.

6. The Bidder attests to and affirms that he and his subcontractors are skilled and experienced in the use and interpretation of plans, specifications, addenda and related Bid Documents and, that he has carefully reviewed the plans, specifications, addenda and related Bid Documents for this project and has found them to be free of conflicts and/or ambiguities and sufficient for bidding and construction purposes. Further, he has carefully examined the soils reports and the site of the work, and, through his own person observations, has satisfied himself as to the nature, location and requirements of the work; the character, quality and quantity of materials required; the difficulties likely to be encountered; the other items and/or conditions which may affect the satisfactory performance of the work. He has based his bid solely on these documents, and personal observations, and has not relied in any way on any explanation or interpretation, oral or written, from any source other than who's written and issued by the Owner.

Bidder agrees that the Owner has the right to accept or reject any or all bids and to waive all informalities.

Respectfully Submitted,

By: _____ Date _____, 20 _____
(Signature)

(Printed Name)

(Title)

(Company)